

# SERIE SPS

TYPE

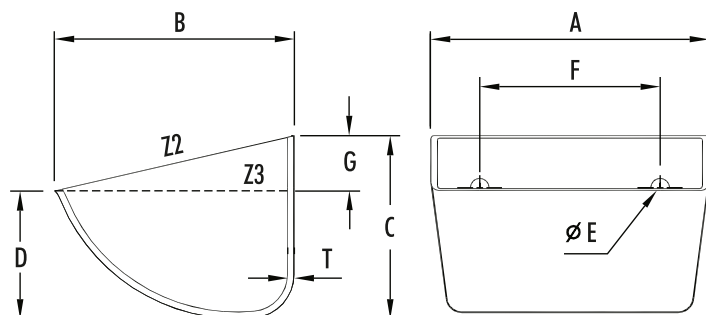

**HDP POLIETILENE ALTA DENSITÀ  
NY NYLON 6**

**HDP HIGH DENSITY POLYETHYLENE  
NY NYLON 6**

Tazza Bucket	A	B	C	D	T	Peso Weight	Capacità (Litri) Capacity (Litres)		N° fori N° of holes	E	F	G	tz/m bk/m
	mm	mm	mm	mm	mm	Kg*	Z2	Z3	Bombati Recessed	Ø mm	mm	mm	Max
SPS 80-80	91	85	64	45	5,0	0,08	0,24	0,20	2	9	43	18	15
SPS 100-90	110	100	68	46	5,0	0,11	0,39	0,32	2	9	50	20	14
SPS 120-100	130	110	80	56	5,0	0,14	0,61	0,48	2	9	67	25	12
SPS 130-120	135	121	85	55	5,0	0,21	0,72	0,54	2	9	70	25	11
SPS 130-130	146	130	89	60	5,0	0,20	0,88	0,68	2	9	70	25	10,8
SPS 140-120	146	120	90	60	6,0	0,18	0,81	0,62	2	8,5	70	25	10,8
SPS 160-140	172	152	113	80	7,0	0,34	1,55	1,25	2	9	100	30	8,6
SPS 180-140	187	150	112	78	5,0	0,29	1,79	1,42	2	9	100	30	8,6
SPS 200-150	202	154	112	74	8,0	0,35	1,89	1,39	2	9	100	30	8,6
SPS 200-160	210	160	123	85	7,0	0,47	2,23	1,77	2	9	100	30	8
SPS 230-170	240	175	137	96	7,0	0,56	3,09	2,42	2	11	120	36	7
SPS 240-165	250	168	130	92	6,0	0,53	3,12	2,43	2	11	120	35	7,4
SPS 280-165	292	170	131	94	7,0	0,63	3,75	3,06		**			7,4
SPS 280-170	282	175	137	97	7,0	0,66	3,77	2,96	3	11	80	34	7
SPS 280-180	290	185	140	97	8,0	0,83	4,21	3,34		**			7
SPS 300-150	305	152	115	78	7,0	0,60	2,92	2,28		**			8,3
SPS 300-150-RH	305	152	115	78	7,0	0,60	2,92	2,28	4	9	51-102-51	32	8,3
SPS 300-180	314	185	140	100	8,0	0,84	4,69	3,79		**			7
SPS 300-215-RH	318	220	166	120	9,0	1,19	6,66	5,38	3	11	100	50	5,88
SPS 330-180	350	185	140	98	8,0	0,95	5,30	4,10		**			7
SPS 330-215	343	218	168	120	9,0	1,28	7,05	5,81		**			5,88
SPS 330-215-RH	343	220	168	120	9,0	1,28	7,23	5,86	3	11	120	50	5,88
SPS 350-180	370	186	138	102	8,5	1,07	5,35	4,27		**			7
SPS 350-215-RH	368	218	166	120	9,0	1,39	7,84	6,39	3	11	120	50	5,88
SPS 370-215	391	219	167	123	9,0	1,45	8,45	6,75		**			5,88
SPS 370-215-RH	390	221	168	115	9,0	1,42	8,45	6,48	4	11	90	50	5,88
SPS 400-215-RH	423	220	167	116	9,0	1,52	9,18	7,29	4	11	100	50	5,88
SPS 450-215	470	219	166	110	9,0	1,58	9,73	7,70		**			5,88
SPS 450-215-RH	468	220	167	120	9,0	1,61	9,95	7,82	5	11	90	50	5,88
SPS 500-215	530	218	167	120	9,0	1,87	11,27	9,11		**			5,88
SPS 500-215-RH	528	221	168	117	9,0	1,92	11,62	9,10	5	11	100	50	5,88

\* Peso delle tazze: Nylon +25%

\*\* Foratura su richiesta (fori piani)

\* Buckets weight: Nylon +25%

\*\* Drilling on request (flat holes)